

OCC  *Outdoors*

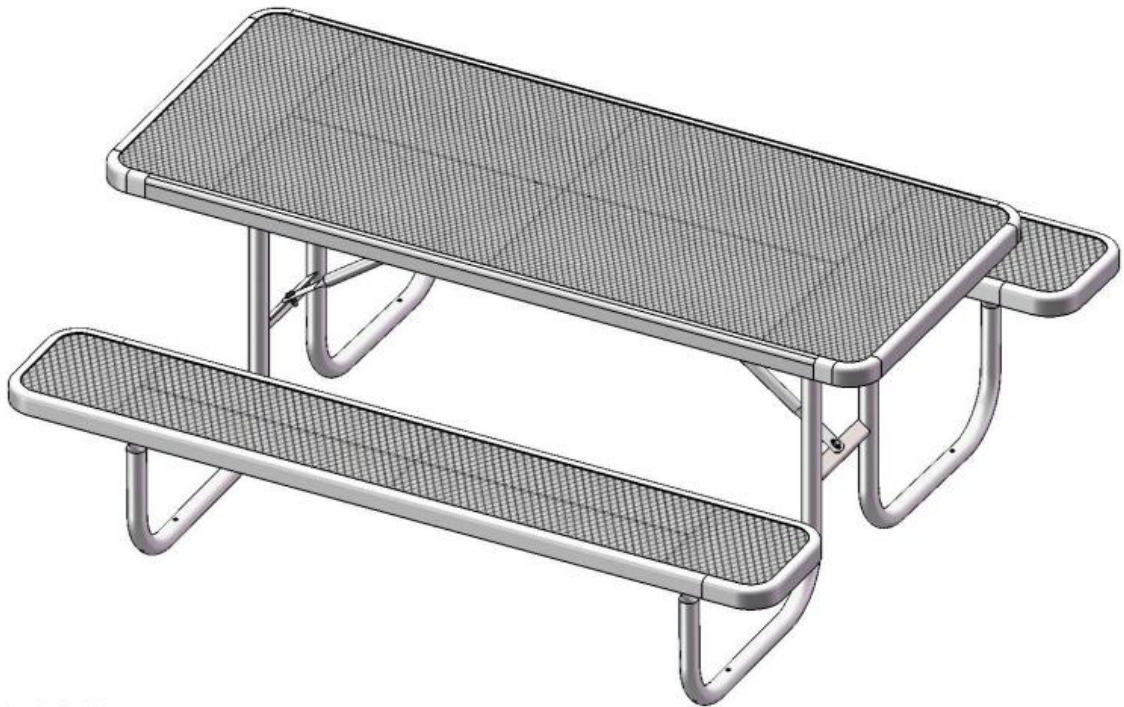

Model # 158-V6

## HARDWARE



5/16" x 1"  
Machine Bolt



5/16" Washer



5/16" Kep Nut

## TOOLS REQUIRED

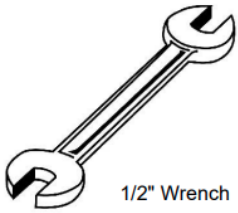

1/2" Wrench

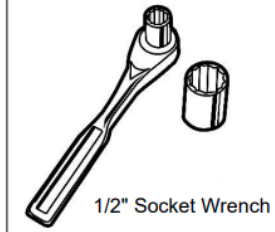

1/2" Socket Wrench



Tape Measure

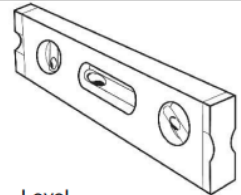

Level

## ULTRA SITE PRODUCT SPECIFICATIONS

### **158-V6 6' PORTABLE PICNIC TABLE WALK-THROUGH DESIGN**

Top & Seats: 11 gauge die formed angle frame 1"x1-7/8" with 3" radius corners. 3/4" #9 steel expanded metal. 7 gauge x 1-1/2" flat bar center support and mounting bracket understructure. Electrically MIG welded.

Coating: Oven fused functionalized polyethylene copolymer-based thermoplastic. Fluidized bed coating application with superior mechanical performance, impact resistance and UV-stability.

Frame: 1-5/8" O.D. x 14 gauge pre-galvanized structural steel tubing. Cross braces 1" O.D. x 16 gauge pre-galvanized structural steel tubing. Brace attachment points 1-1/2"x1-1/2"x3/16" steel angle. Seat and top mounting points 7 gauge x 1-1/2" die stamped steel flat bar. Legs are bent over a mandrel through the bend radius producing a wrinkle free bend. All electrically MIG welded.

Frame Coating: Electrostatic powder coated application oven cured.

Hardware: All stainless steel hardware fasteners.

Dimensions: 6' portable picnic table walk-through design. Top is 30" wide x 72" long and is 30-1/4" high. Seats are 12" wide x 72" long and 18-1/4" high. Outside to outside dimension is 64-3/4" x 72".

## COMPONENTS

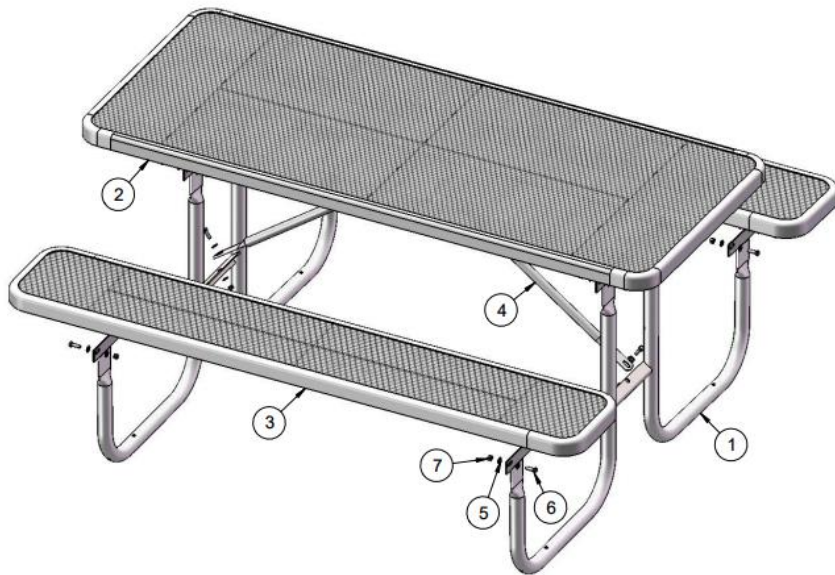

ITEM NO.	Part No	DESCRIPTION	QTY
1	P-V158	158 Vinyl Frame	2
2	T-V72-T	6' Expanded Top	1
3	T-V72-S	6' Expanded Seat	2
4	P-01-04-0125	29 7/8" Brace	2
5	33-02-0007	5/16" Flat Washer (SS)	40
6	33-05-0029	5/16" x 1" Machine Bolt (SS)	20
7	33-03-0012	5/16" Kep Nut (SS)	20

Optional Surface Mount Hardware:  
5/16" x 4" Concrete Expansion Anchor Bolts  
(Not Included)

## STEP 1

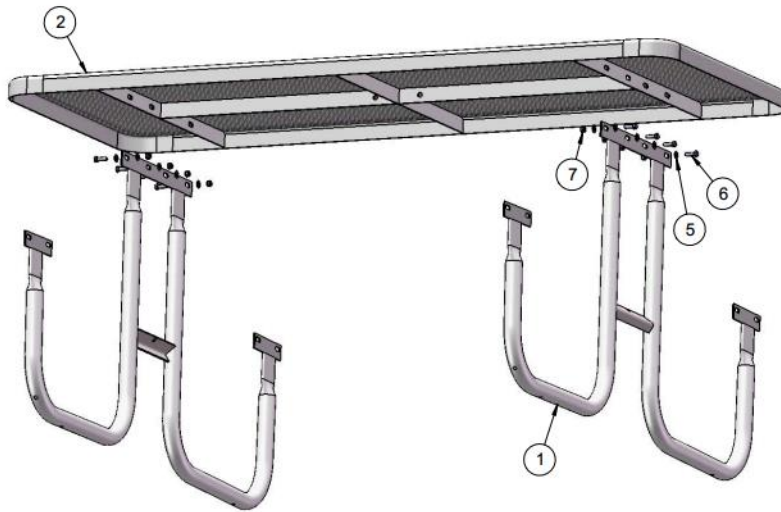

Attach the 6' Top to the 158 Legs using specified hardware.

## STEP 2

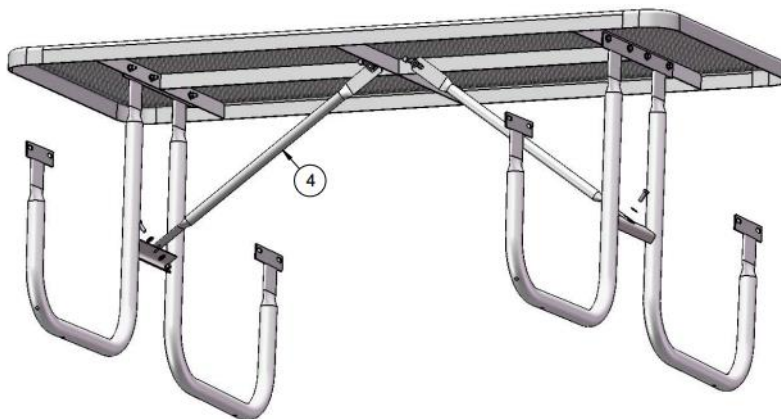

Attach the 29-7/8" Braces to the Legs and Top using specified hardware.

### STEP 3

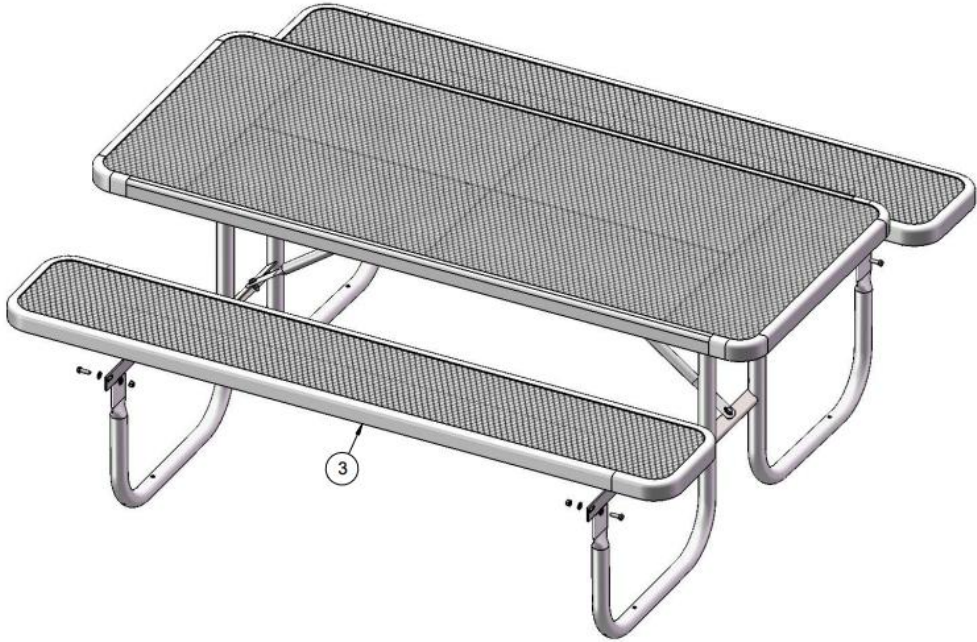

Attach the 6' Seats to the 158 Legs using specified hardware.

### OVERALL DIMENSIONS

