

# Backed Bench Anchoring Instructions

## Tools Required:

1. Cordless Drill
2. 1/8" Drill Bit
3. 1/2" Wrench (Socket works best)

## Step #1:

Make sure all components are included:

Qty. 8 - 5/16" x 1-1/4" Hex Head Lag Bolt

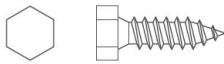

Qty. 4 - Aluminum Anchor Plates

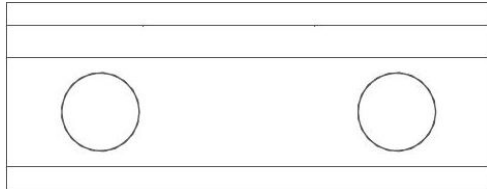

## Step #2:

After your bench is completely assembled, place the aluminum anchor brackets onto the inside center of the two outer bench legs and mark the hole placement for drilling the pilot holes.

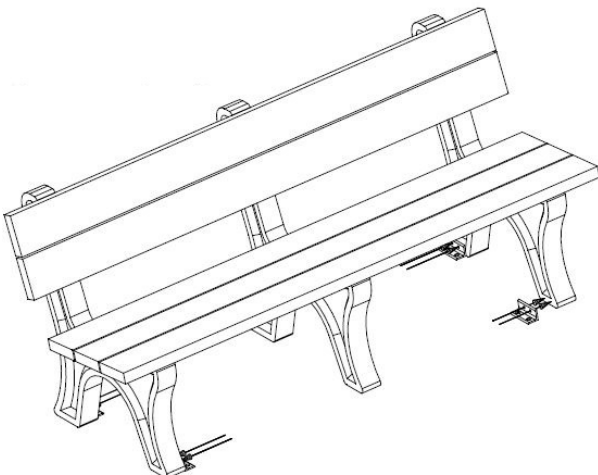

**Step #3:** Remove the aluminum anchor plates and drill a 1/8" diameter hole 3/8" deep into the previously marked locations on the bench ends.

Note: the view has been altered to show detail.

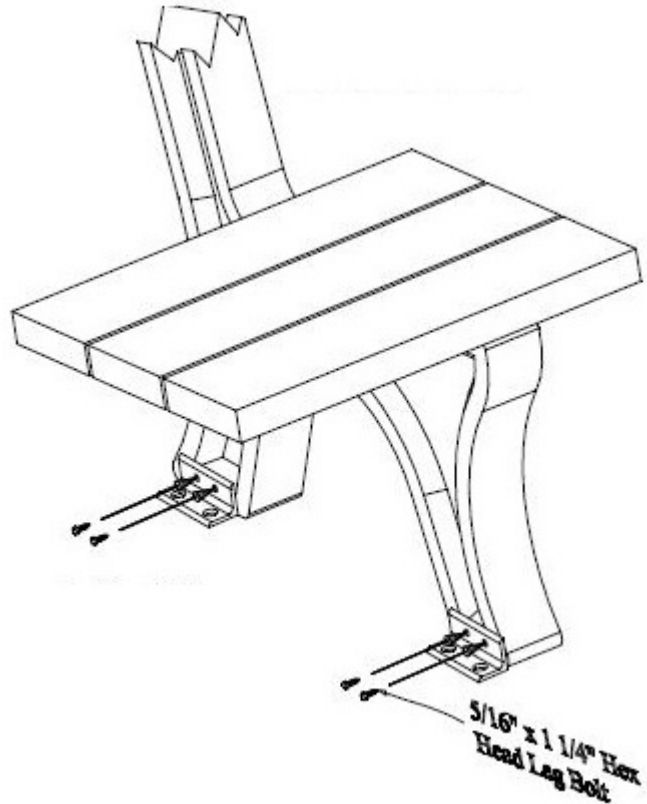

## Step #4:

After the holes are drilled, line up the aluminum brackets and using the 1/2" wrench fasten the 5/16" x 1-1/4" Hex Head Lag Bolts provided as shown.

## Step # 5:

Place your bench in place and anchor into place from the anchor manufacturer. Anchors are not included due to different applications. Please see your hardware store to get the proper anchor for your application