

Econo-Mizer Planter Box

For Fastener Pack
(FP-EMP-CU-01)

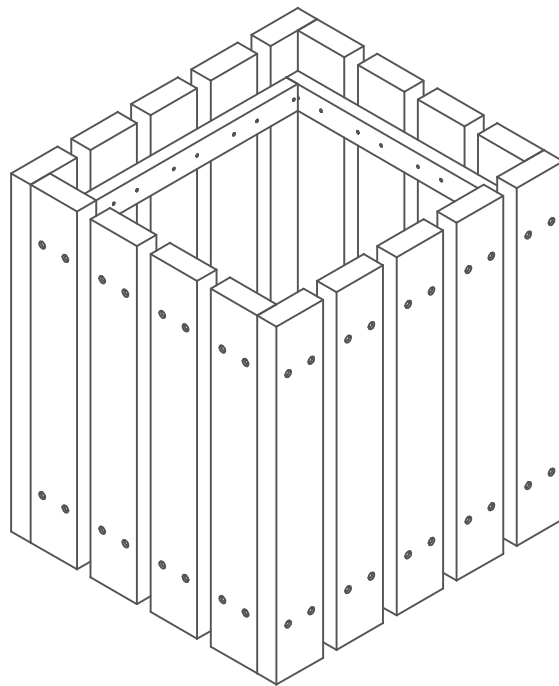

Congratulations ! !

You have just purchased the finest recycled plastic
planter box available. Enjoy ! ! !

Before assembly, please make sure all components are included.

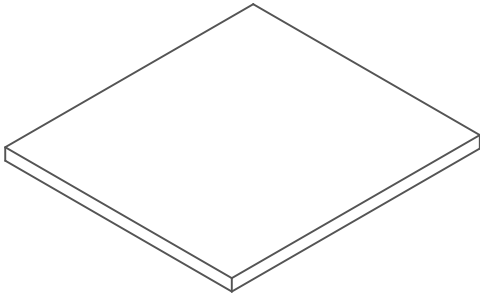

(1) - Flat Top
TRP-EMTP-F-01

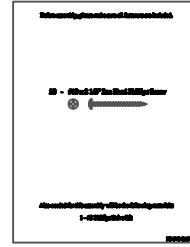

FP - Fastener Pack

(1) - One Fastener Pack
FP-EMTP-CU-01

(2) - Two Frame Rings
PBSA-EMT-A-01

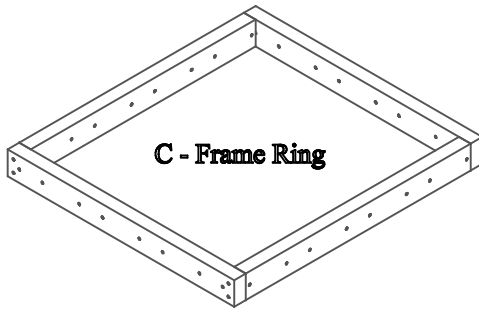

C - Frame Ring

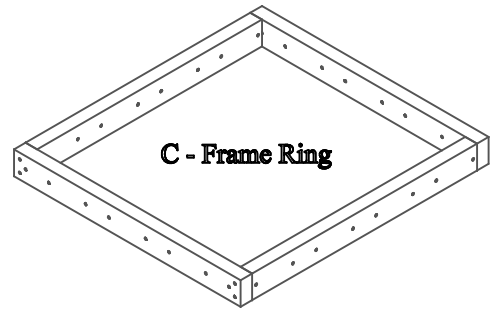

C - Frame Ring

◦	A - Side Board	◦
◦	A - Side Board	◦
◦	A - Side Board	◦
◦	A - Side Board	◦
◦	A - Side Board	◦
◦	A - Side Board	◦
◦	A - Side Board	◦
◦	A - Side Board	◦
◦	A - Side Board	◦
◦	A - Side Board	◦

◦	A - Side Board	◦
◦	A - Side Board	◦
◦	A - Side Board	◦
◦	A - Side Board	◦
◦	A - Side Board	◦
◦	A - Side Board	◦
◦	A - Side Board	◦
◦	A - Side Board	◦
◦	A - Side Board	◦
◦	A - Side Board	◦

(18) - Sixteen Side Boards
PBP-EMTP-A-01

Before assembly, please make sure all fasteners are included.

72 - #12 x 2" Flat Head Phillips Screw



Also needed for this assembly will be the following materials:

1 - #3 Phillips Drive Bit

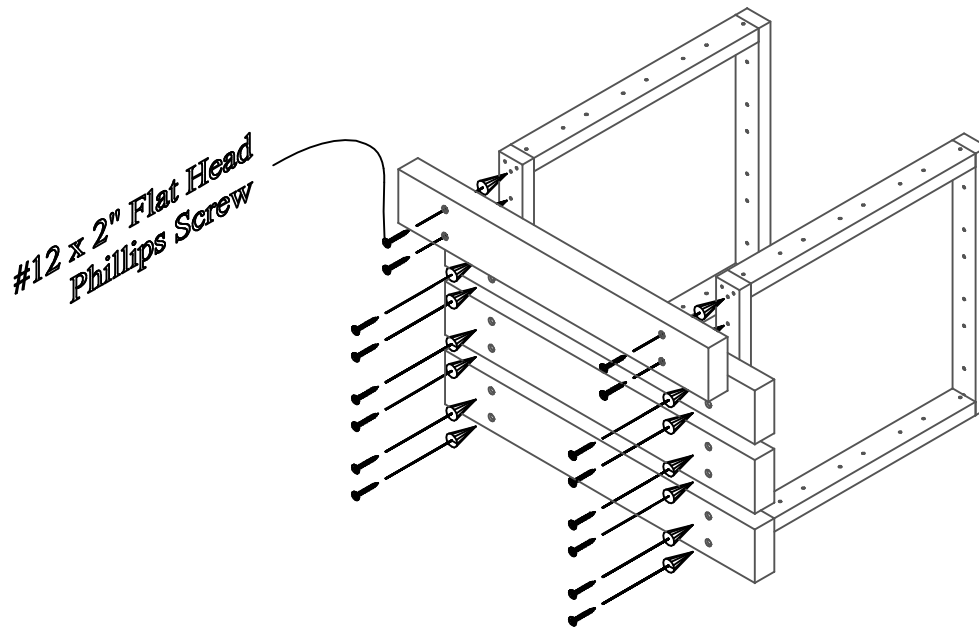

Step #1:

Place the (2) two Frame Rings on edge with the long edge on a flat surface as shown in the diagram above. One at a time, place (4) four Side Boards in position making sure the holes line up with the pre-drilled pilot holes in the Frame Rings. Fasten using (1) one 2" Flat Head Phillips Screw per hole.

*#12 x 2" Flat Head
Phillips Screw*

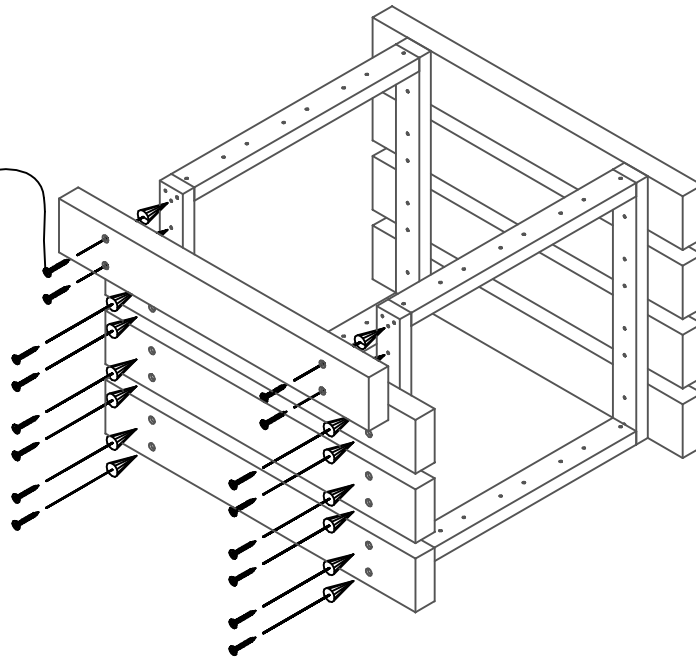

Step #2:
Repeat Step #1 for the opposite side.

Step #4:

One at a time, place (5) five Side Boards in position making sure the holes line up with the pre-drilled pilot holes in the Frame Rings. Fasten using (1) one 2" Flat Head Phillips Screw per hole.

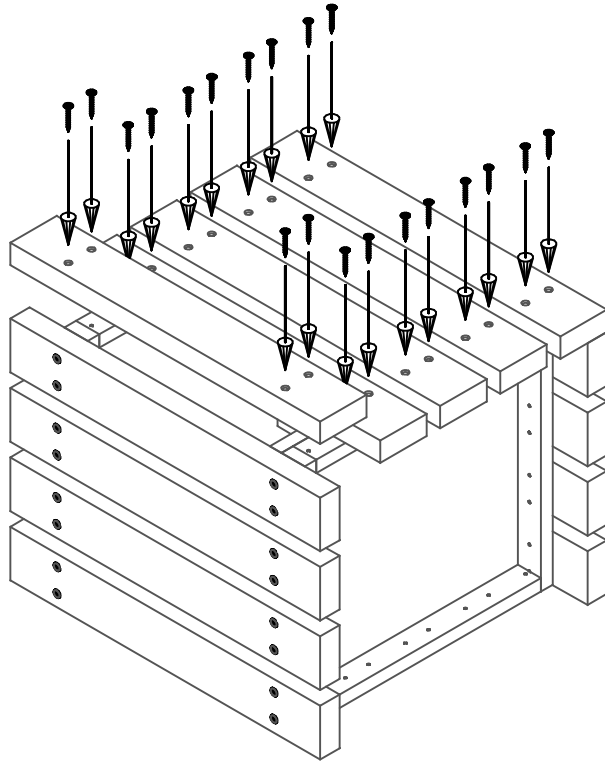

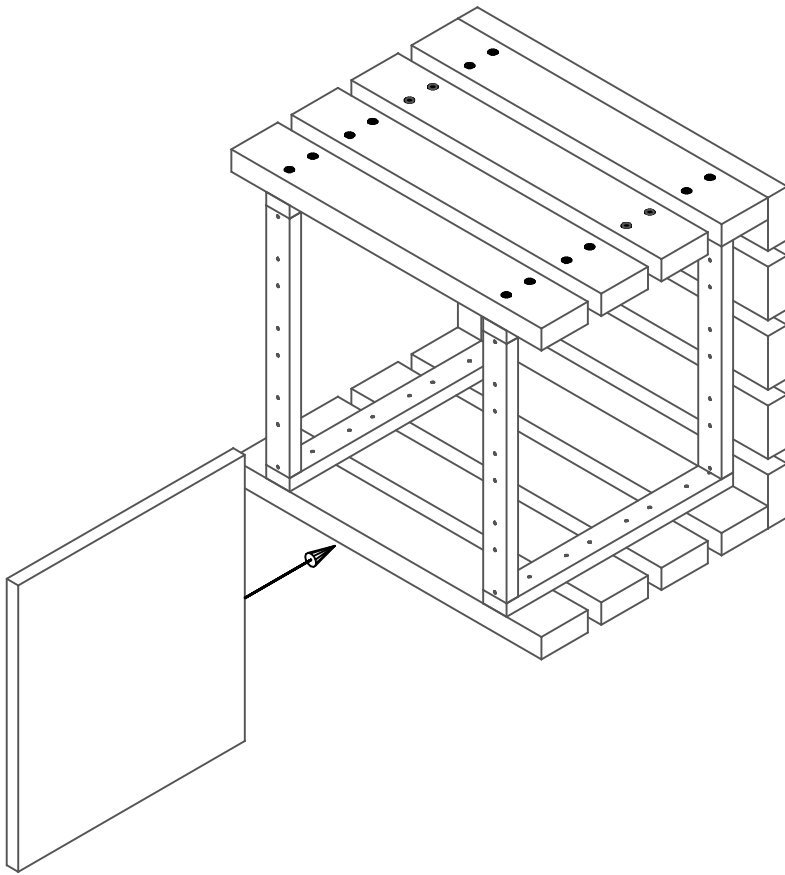

TRP-EMTP-F-01

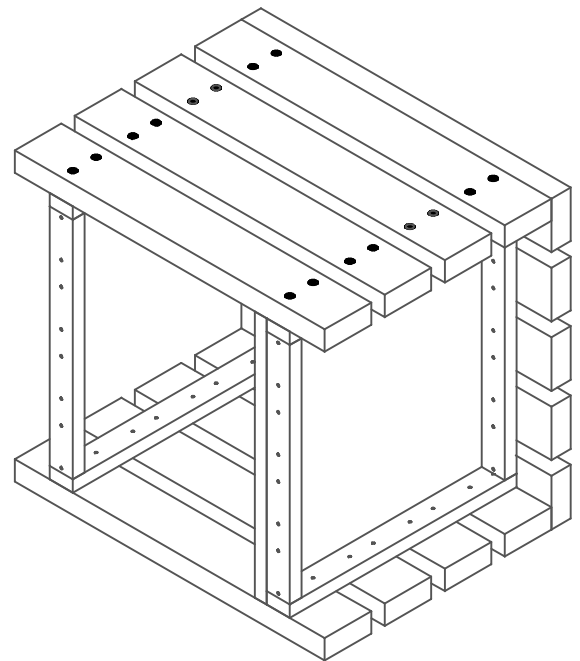

Step #5:

On the open side of the Planter Box, insert the "TRP-EMTP-F-01" into the planter box as shown, making sure it is rotated the correct way.

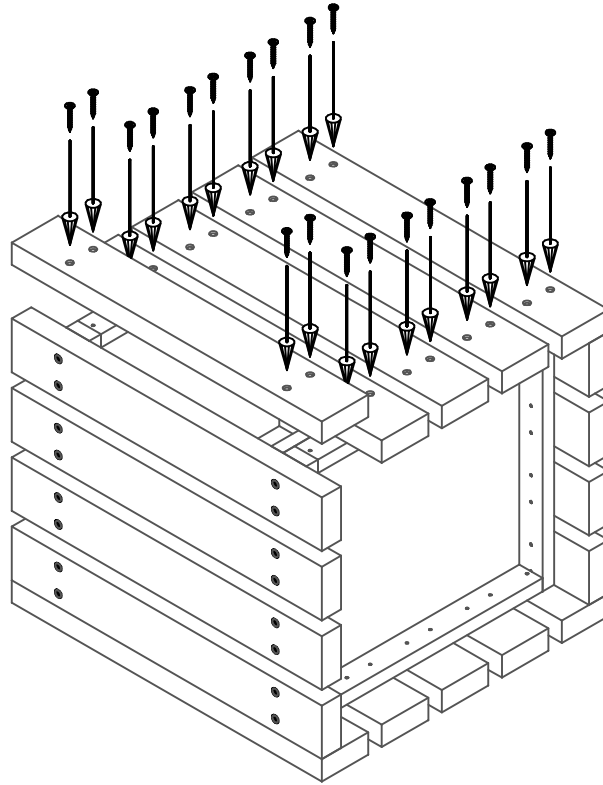

Step #6:

One at a time, place (4) four Side Boards in position making sure the holes line up with the pre-drilled pilot holes in the Frame Rings. Fasten using (1) one 2" Flat Head Phillips Screw per hole.

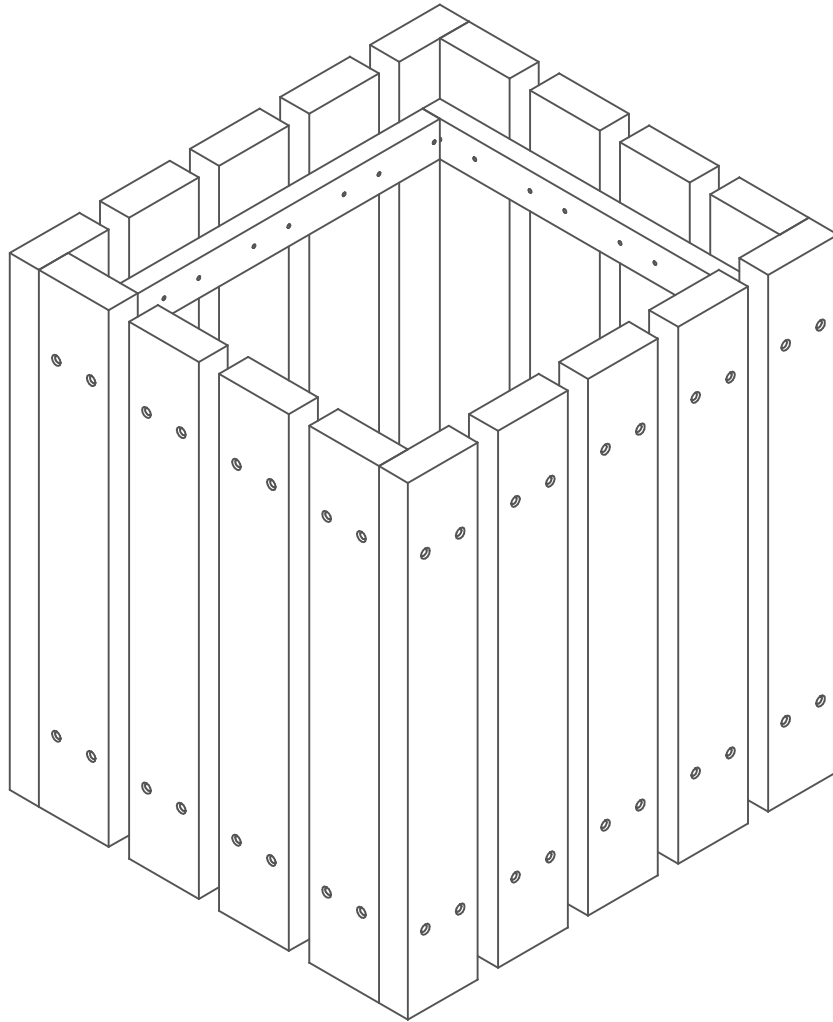

Flip it to the up right position and your planter box is now complete.