

**Tools Required**

**Parts**

**Dimensions**

**Hardware Included**

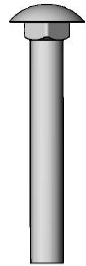

5/16" x 2-1/4" Carriage Bolt



3/8" x 1-3/4" Carriage Bolt

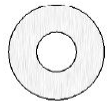

5/16" Washer

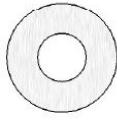

3/8" Washer



5/16" Hex Nut



3/8" Hex Nut

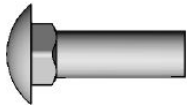

3/8" x 1-1/4" Carriage Bolt

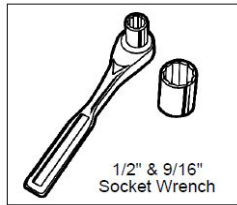

1/2" & 9/16" Socket Wrench

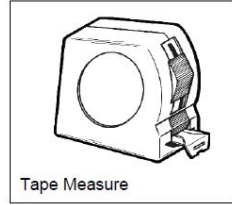

Tape Measure

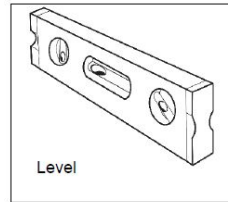

Level

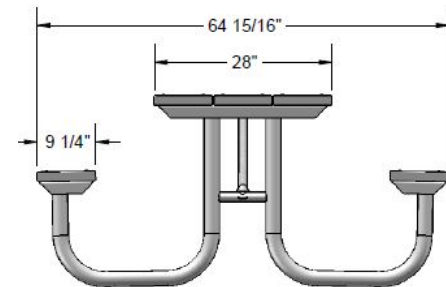
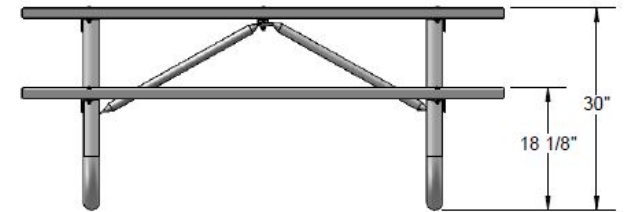
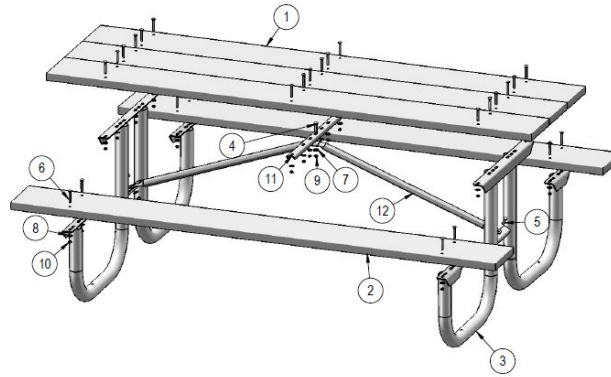

**Note:** Optional Surface Mount Hardware: 5/16" x 5-1/2" Concrete Expansion Bolts Not Included.

**WARRANTY:** OCCOutdoors, Inc. guarantees all items for one full year to be free of defects in workmanship or materials when installed and maintained properly. We agree to repair or replace, any items determined to be defective. Items specifically not covered by this warranty include vandalism, manmade or natural disasters, lack of maintenance, normal weathering or wear and tear due to public abuse.

**NOTES:**

1. INSTALLATION TO BE COMPLETED IN ACCORDANCE WITH MANUFACTURER'S SPECIFICATIONS.
2. ALL DIMENSIONS ARE CONSIDERED TRUE AND REFLECT MANUFACTURER'S SPECIFICATIONS
3. DO NOT SCALE DRAWING.

This document contains OCC Outdoors Proprietary Information. No intellectual copyright or license is granted by OCC Outdoors in connection with it. It is delivered on the express condition that the document and the information contained in it shall be treated as confidential, shall not be used for and purpose other than that for which it is hereby delivered (the use and maintenance of the product supplied). It shall not be disclosed in whole or part to third parties and shall not be duplicated in any manner without OCC Outdoors's prior approval.

**OCC Outdoors Products**

PH: 1-800-821-7670  
 EMAIL - occcontact@occoutdoors.com  
 Fax: 1-317-862-9422

**Part #: OCC-238-R8**

Date: 4/12/16 Page 1 of 2

**OCC Extra Heavy Duty 8' Picnic Table with Recycled Plastic Planks, Powder Coated Frame, & Walk Through Design. Can be Portable or Surface Mounted.**

**Assembly Instructions:**

**Step 1:**

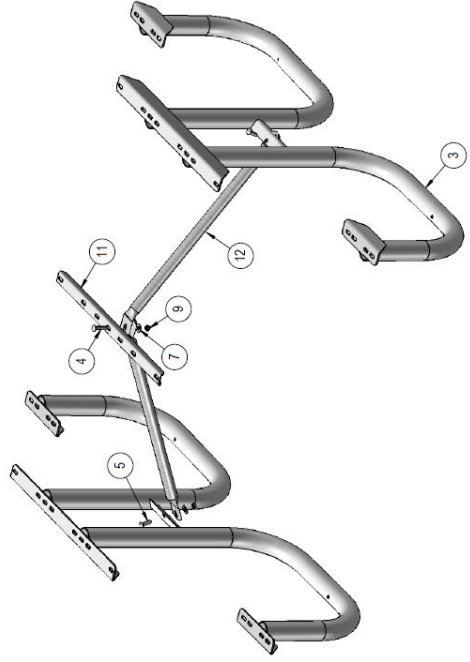

**Attach the 6' Wood Braces to the Center C Channel and the 238 Legs using the specified Hardware.**

**Step 2:**

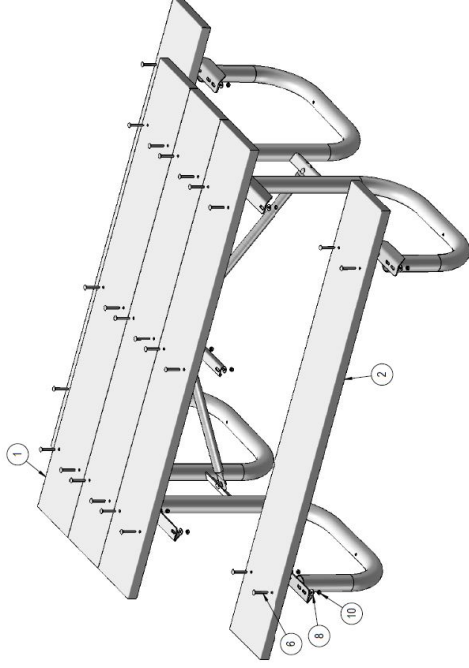

**Attach the 6' Seat Planks and the 6' Top Planks to the 238 Legs using Specified Hardware**