



Proudly made in the USA



Circle



1-Loop



3-Loop



5-Loop

MODEL #	DESCRIPTION	Colors See page 2 for Paint and Zinc Advantage Details	SIZE L x W x H	Weight:	BIKE Capacity
Bike - Circle	Circle Bike Rack	Black, Bronze, Silver Gray, Green, Blue, Burgandy	35 x 2-1/2 x 33	28	2
Serp-1-Loop Rack	1-Loop Wave Style Bike Rack	Black, Bronze, Silver Gray, Green, Blue, Burgandy	22 x 2 1/2 x 34"	27	3
Serp-3-Loop Rack	3-Loop Wave Style Bike Rack	Black, Bronze, Silver Gray, Green, Blue, Burgandy	43 x 2 1/2 x 39"	56	5
Serp-5-Loop Rack	5-Loop Wave Style Bike Rack	Black, Bronze, Silver Gray, Green, Blue, Burgandy	68 x 2 1/2 x 39"	80	7

Construction Details:

- Loops are 2-3/8 10-gauge steel tubing bent over a mandrel through the bend radius producing a wrinkle free bend.
- Surface Mounting Plates are 10 Gauge x 6" diameter and are MIG welded to the end loops.
- Mounting hardware is included (3/8" Dia. Lag Bolts)
- Mounting Holes are Pre-Drilled.
- See page 2 for OCC's zinc Advantage and Powder Coat Paint Proess/Colors
- **Made In The USA**

Installation Instructions

1. Place the bike rack in it's desired location and mark the center of the holes in each flange on the mounting surface.
2. Set aside the bike rack and using a 5/8" masonry bit drill holes where marked 2" deep.
3. Blow the dust and any other debris out of the hole and insert the anchor shields into the holes and gently tap into place with a hammer.
4. Align the holes in the flange with the anchors and secure with 3/8" lag bolts.

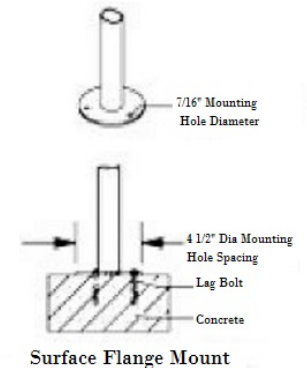

OCCOutdoors, Inc. Warranty: 20 Years Structural and one year paint when installed and maintained properly. We agree to repair or replace, any items determined to be defective. Items specifically not covered by this warranty include vandalism, man-made or natural disasters, lack of maintenance, normal weathering or wear and tear due to public abuse.

NOTES:
 1. INSTALLATION TO BE COMPLETED IN ACCORDANCE WITH MANUFACTURER'S SPECIFICATIONS.
 2. ALL DIMENSIONS APE CONSIDERED TRUE AND PEFLECT MANUFACTUPEP'S SPECIFICATIONS
 3. DO NOT SCALE DRAWING.

This document contains OCC Outdoors Proprietary Information. No intellectual copyright or license is granted by OCC Outdoors in connection with it. It is delivered on the express condition that the document and the information contained in it shall be treated as confidential, shall not be used for and purpose other than that for which it is hereby delivered (the use and maintenance of the product supplied). It shall not be disclosed in whole or part to third parties and shall not be duplicated in any manner without OCC Outdoors's prior approval.

OCC Outdoors Products
 PH: 1-800-821-7670
 EMAIL - occcontact@occoutdoors.com
 Fax: 1-317-862-9422

OCC Circle & Serpentine Style Surface Mount Bike Rack

Part #:
 Bike-Serp & Bike-Circle

OCC Colors and Paint Details

Bench Colors: OCC offers hundreds of color including the standard RAL colors, Architectural series and custom mixed colors. Please contact us with you color requirements. For more details please go to: www.occoutdoors.com/blog/understanding-nonstandard-colors-cost.

Black (RAL 9005)



Bronze (C33)

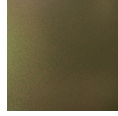

Silver Gray (70049)



Green (RAL 6005)



Blue (RAL 5012)



Burgundy (RAL 3004)



Color Matching Information: OCCOutdoors makes every effort to present the planter colors as accurately as possible. The planter colors have been produced electronically and are provided for general color information and illustration purposes only. Because of the differences in computer monitors, printers, other hardware and software combinations, the depicted results are intended to be used as approximations of color and not as definitive representations and should not be relied upon or used as such. We cannot guarantee you will achieve desired results without verifying an actual color sample of your actual color selection. For specific advice regarding your project, we recommend that you contact OCC Outdoors: Phone: 1-800-821-7670 email: occcontact@occoutdoors.com

Zinc Advantage Process Details:

Zinc rich primer & Super TGIC powder coat Finishing operations.

1. Sand blasts each unit down to shiny metal.
2. Clean and hand inspects each unit.
3. Powder coat with 70 % zinc rich epoxy resin primer.
4. Partially bake the primer.
5. Powder coat with SUPER TGIC Polyester finish coat.
6. Final bake, creating a molecular bond between the steel, primer and finish coat.
7. Each part is tested by a Xylene test to insure a complete cure.

Advantages:

1. A very tough durable finish with 5 times the fade resistance of standard TGIC powder coatings with a 3H pencil hardness. (All test conducted in South Florida.)
2. If scratched through to the metal, the zinc rich primer greatly reduce rust and the potential for the migration of rust.
3. This system is cured and each unit test for cure so many types of paint used for graffiti can be clean with mild solvents.

Our paint manufacturer's Zinc Rich Primer TGIC Polyester out lasts all major competitors on the 4000 hour salt spray test per ASTM B117. Detailed reports available by request.